

**tradetested**

# GARDEN SHED MANUAL GS503-V1

Shed Size at Roof: 3070x1000x1920mm  
Shed Size at Floor: 3070x790x1900mm  
Door Size: 1750x1480mm  
Internal Shed Size at Floor: 3030x750mm

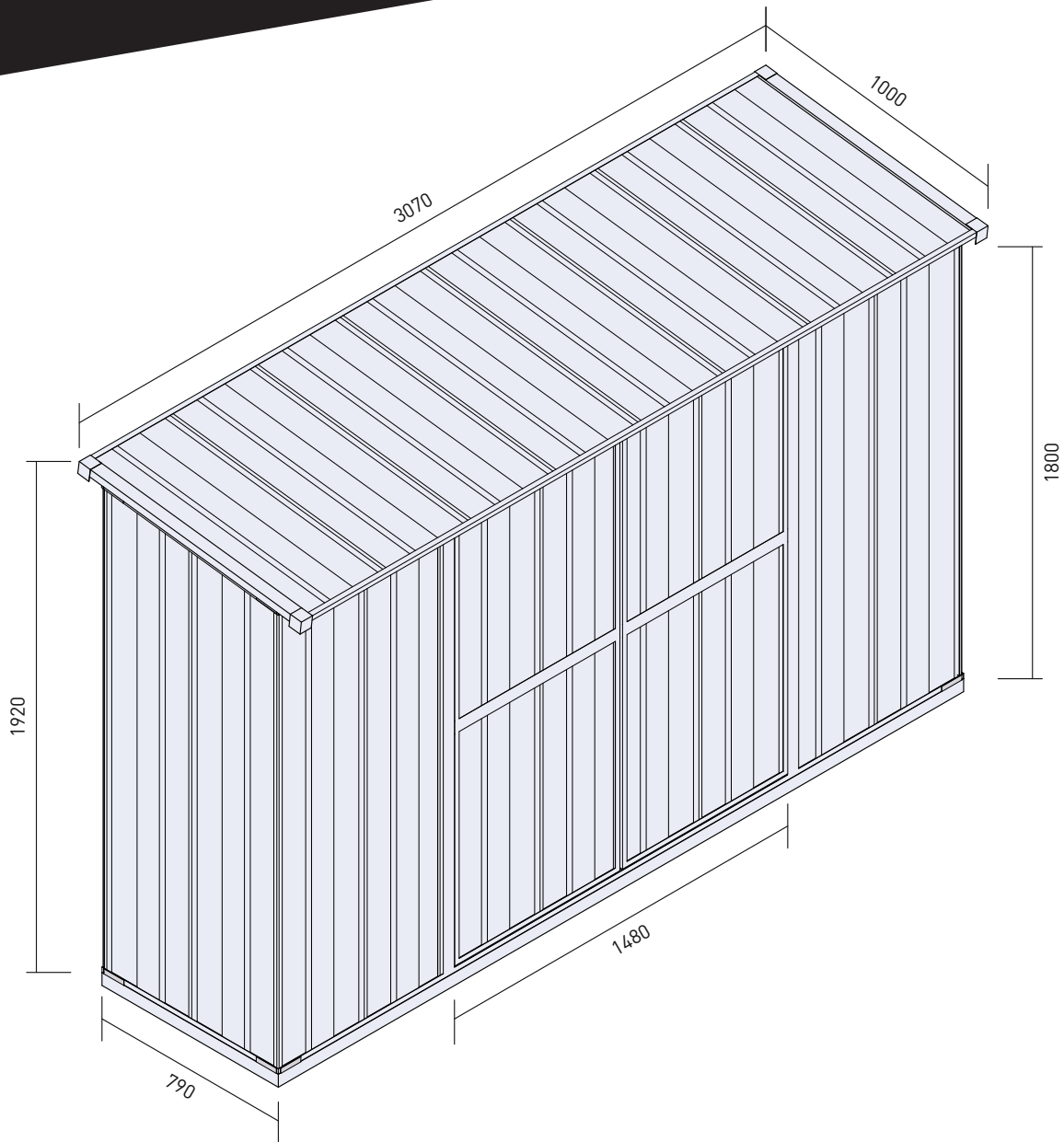

## Before you begin

---

- Check local building codes regarding shed location and any other local requirements.
- Check the packing list on page 4 to make sure you have all of the necessary parts.
- Separate everything in the cartons by the part number while reviewing the parts list.
- Be sure the day you select to build your shed is dry and calm.
- Whenever possible, two or more people should work together to assemble the shed. We suggest that one person positions parts while the other handles the fasteners and tools.

## Selecting & Preparing Your Site

---

Before assembly, decide on a location for your shed. We recommend a level area with good drainage. Allow enough space around the building so there's plenty of room to screw the panels and move the different parts into position. Remember to leave plenty of room for the door to fully open.

## You Will Need...

---

- An electric drill/driver
- A Phillips screwdriver
- Gardening or work gloves
- Sealant or caulking gum (optional)
- Step ladder
- Tape measure

## Safety First

---

Safety precautions are important to follow throughout the construction of your building.

- Take care when handling the various pieces of your building since some contain sharp edges. Please wear work gloves, eye protection and long sleeves when assembling or performing any maintenance.
- Keep children and pets away from your worksite to avoid distractions and any accidents.
- Never concentrate all your weight on the roof of the structure. When using a step ladder make sure it's fully open and on a level surface.
- To avoid any damage, do not attempt to assemble the building on a windy day. The larger panels can act as sails making construction difficult and unsafe.

# Flooring & Foundations

---

A solid shed starts with a level floor and foundation. This is the single most important factor in making your shed as watertight and stable as possible. It also makes the assembly process as simple as possible. We recommend the following foundation options:

## Option 1 - Wooden Floor

We sell wooden floor kits designed to match your shed. Alternatively you can build your own using H4 treated bearers and timber floorboards.

## Option 2 - Concrete Slab

For a more permanent solution, or for large sheds, we recommend a 100mm thick concrete foundation, ideally with a 25mm rebate for walls and corner anchors.

Regardless of which flooring option you choose:

- Build on a compacted and levelled base layer.
- Plastic sheeting placed under the wood or concrete will prevent moisture wicking through.
- We recommend the foundation is the same size as the footprint of your shed to prevent water ingress.

# Assembly Overview

---

Step 1: Check all parts against the parts list

Step 2: Assemble the rear wall

Step 3: Assemble the side walls

Step 4: Assemble the front wall

Step 5: Assemble the roof

Step 6: Assemble the doors

Step 7: Constructing the walls

Step 8: Installing the Bracing

Step 9: Constructing the roof

Step 10: Installing the door

Step 11: Fixing to the floor

Step 12: Finishing touches

# **ASSEMBLY INSTRUCTIONS**

# GS503-V1

## 1 Check all parts against the parts list

### PARTS LIST

Please check your contents prior to starting assembly

ITEM	NAME	SIZE (mm)	QTY	PART #
1	Front Wall	410 x 1800	4	W180
2	Rear Wall	410 x 1900	8	W190
3	Roof Panel	410 x 1000	8	P100
4	Side Wall	410 x 1850 - 1800	1	L185180
5	Side Wall	410 x 1900 - 1850	1	L190185
6	Side Wall	410 x 1800 - 1850	1	R180185
7	Side Wall	410 x 1850 - 1900	1	R185190
8	Rear Wall Channel	1550	4	U155
9	Side Wall Channel	790	4	U079
10	Roof Channel	1550	4	U155
11	Roof Channel	1000	2	G100
12	FrontWall Channel	1550	4	U155
13	Left Door Frame	1800	1	ML180
14	Right Door Frame	1800	1	MR180
15	DoorTop Frame	1480	1	Z148
16	Door Bottom Frame	1480	1	U148
17	Wall Bracing	1300	4	Z130
18	Corner Anchor		8	
19	Hook Anchor		4	
20	Tek Screws		190	
21	Wood Anchor Screws		10	
22	Rivet		100	
23	Corner Cover		4	
24	Spacer		100	
25	Rivet Gun		1	
26	Tek Screwdriver Bit		1	
27	Ø4.0mm Drill Bit		1	
28	Screw Head Sheath		30	
29	Phillips Head Screws		20	

#### DOOR PART

ITEM	NAME	SIZE (mm)	QTY	PART #
30	Door Panel	410 x 1750	2	E175 x 410
31	Door Panel	350 x 1750	2	E175 x 350
32	Door Channel	740	4	U074
33	Door Channel	1750	4	U175
34	Door Square tube	1750	2	D173
35	Door Bar	740	2	H074
36	Door Brace	1110	4	Z111
37	Bolt (door outside)		1	Bolt (door outside)
38	Bolt (door inside)		1	Bolt (door inside)
39	Hinge		4	Hinge



If you're missing anything, just head to [www.tradetested.co.nz](http://www.tradetested.co.nz) and get in touch.

## 2 Assemble the rear wall

a



#W190 x 8  
Rear Wall Panels

- It is helpful to read and understand the full instruction manual before starting.
- For additional helpful Reference Images see page 18 of this manual.
- Select number of panels for rear wall and find flat level ground for assembly.
- Lay the panels out as shown with the large rib overlapping the small.

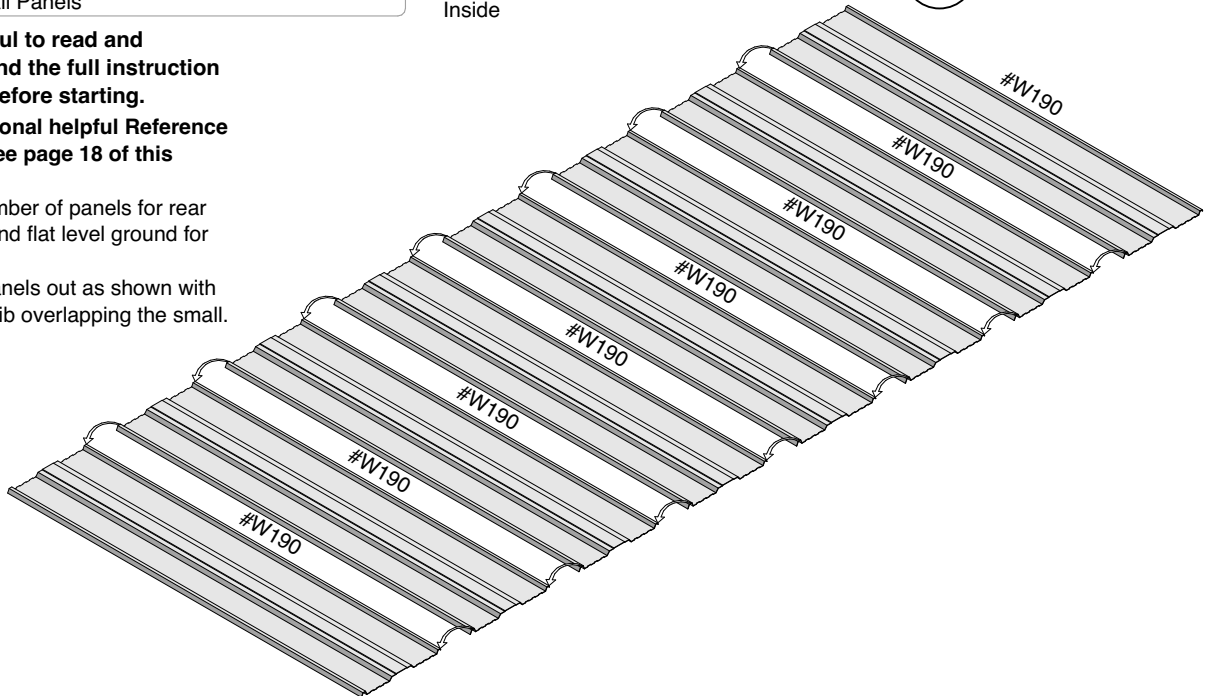

b

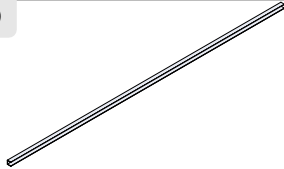

#U155 x 4  
Rear Wall Channels



Profile Shape

- Slide on the rear wall channels until the holes in the top of the channel align with the peaks of the panels. The holes should be up, on the outside face of the shed.
- Check that the panels are pushed hard into the channel and are perpendicular.

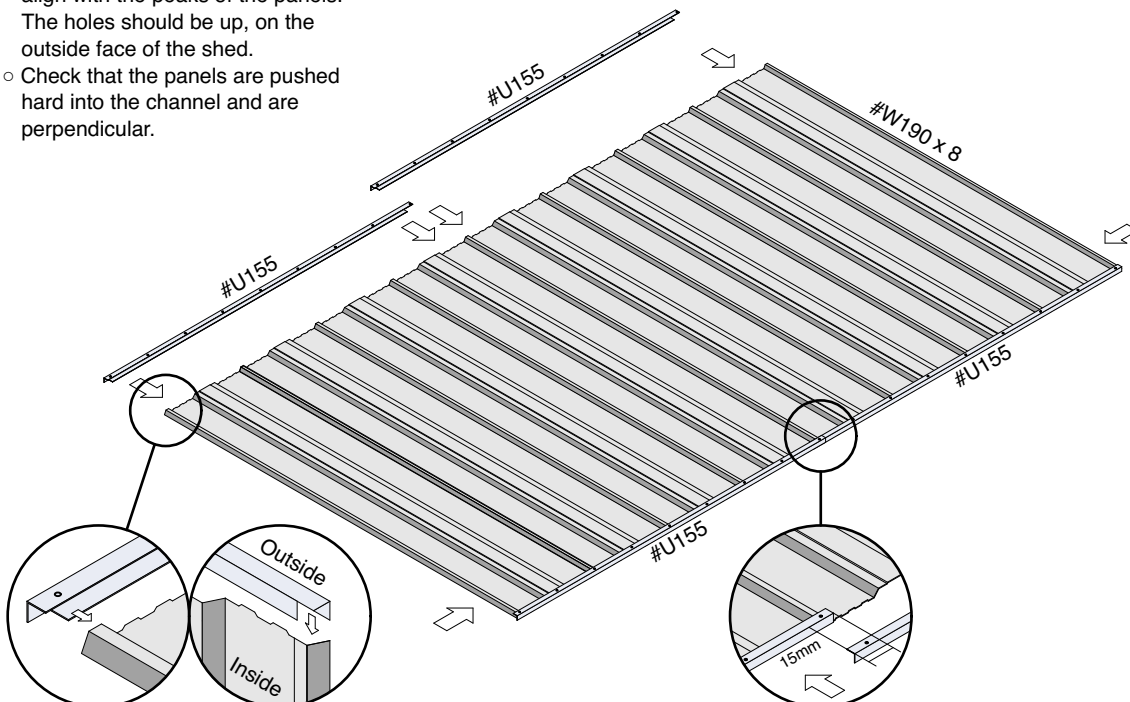

- i All pre-drilled holes should line up with the peaks of the panel. If this varies, squeeze together or stretch out the panels to make sure they align.

## 2 Assemble the rear wall

C



Tek Screws

- The tek screws provided are self drilling, there is no need to create a pilot hole.
- Screw through the channel holes and through the overlapped panels. Make sure the screws go through all layers.
- Do not add screws to the first and last holes. Indicated with an X in diagram. These need to be left undone.
- Once finished, lay the wall flat out of the way.

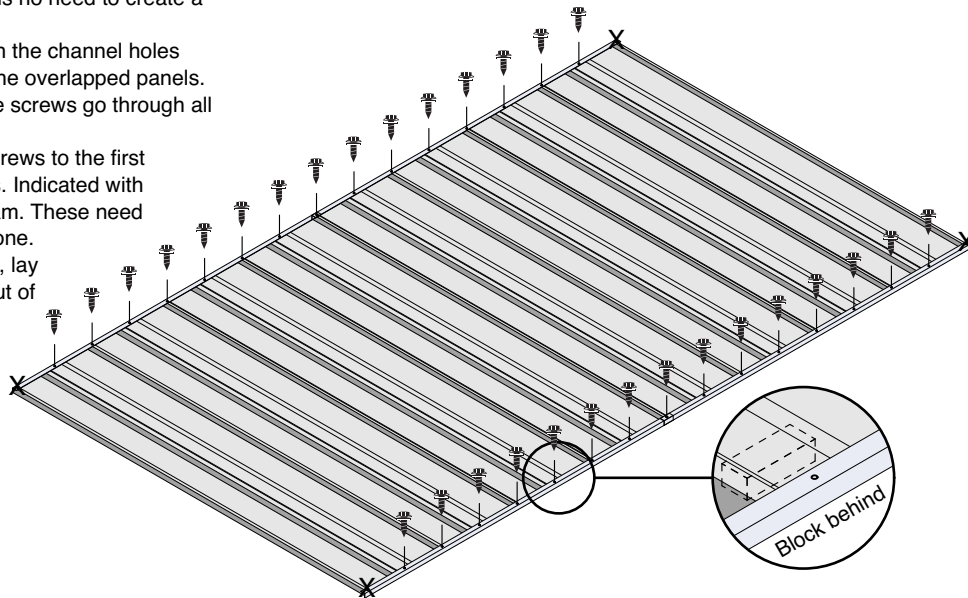

- ① Start with the thin peaks where panel overlaps occur, then move on to the middle of each panel. If needed, use a small wooden block behind the middle of the panel for support while screwing. Make sure the block is not directly underneath the screw.

## 3 Assemble the side walls

a

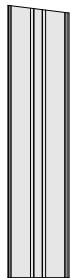

#L190185 x 1  
Side Wall Panel

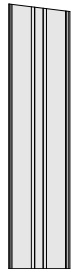

#L185180 x 1  
Side Wall Panel



#R180185 x 1  
Side Wall Panel



#R185190 x 1  
Side Wall Panel

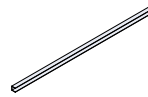

#U079 x 4  
Side Wall Channels



Profile Shape

- Lay the side wall panels out in height order as shown with the large rib overlapping the small.
- Slide on the side wall channels until the holes in the top of the channel align with the peaks of the panels.
- Check that the panels are pushed hard into the channel and are perpendicular to edge.

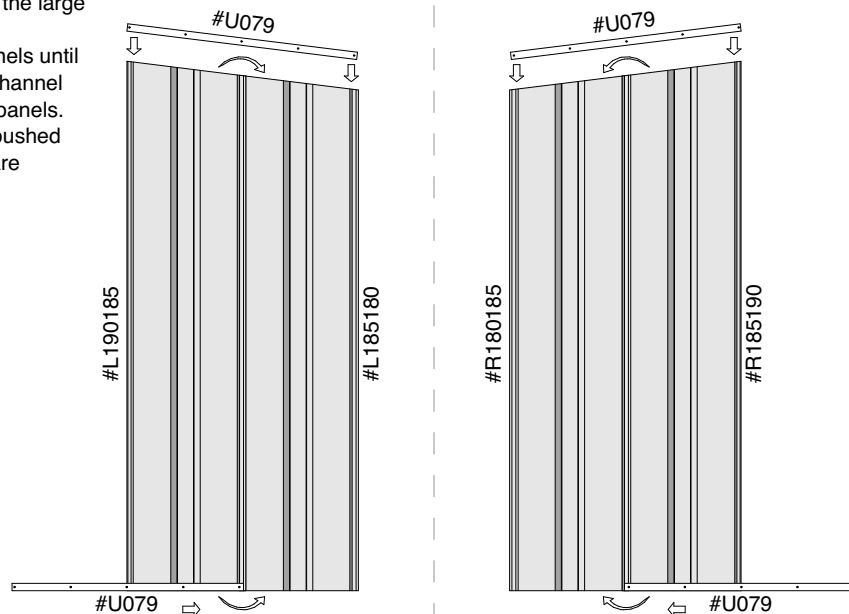

### 3 Assemble the side walls

b



Tek Screws



Profile Shape

① Start with the thin peaks where panel overlaps occur, then move on to the middle of each panel. If needed, use a small wooden block behind the middle of the panel for support while screwing.

- Screw through the channel holes and the overlapped panels. Make sure the screws go through all layers. It is easier to begin with the bottom channel.
- The top of the panel is angled, the cover of the channels allows for slight differences in panel length.
- Do not add screws to the first and last holes. Indicated with an X in diagram. These need to be left undone.
- Once finished, lay the walls flat out of the way.

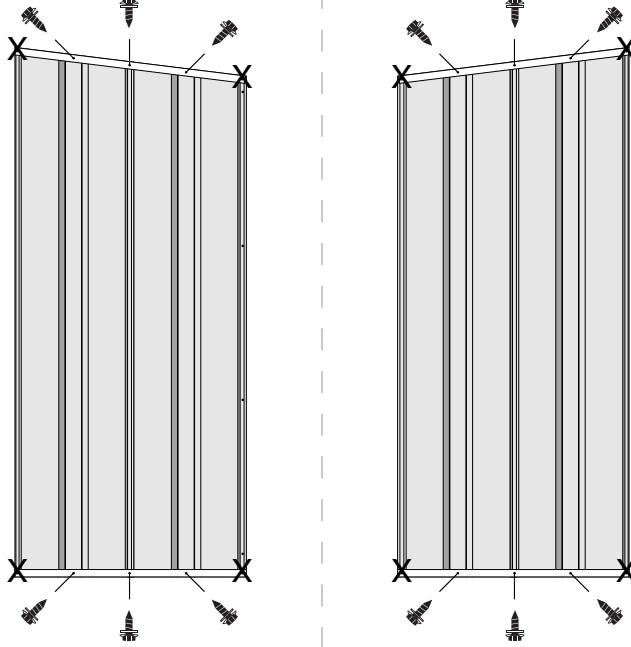

### 4 Assemble the front wall

a



#W180 x 4  
Front Wall Panels

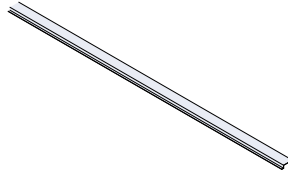

#ML180 x 1 + #MR180 x 1  
Left + Right Door Frame



Profile Shape

- Lay the front wall panels out as shown with the large rib overlapping the small.
- Place the front wall #ML180 and #MR180 door frames over the #W180 wall panels. Mirrored. Have the pre-drilled holes in the door frames on the panel side.

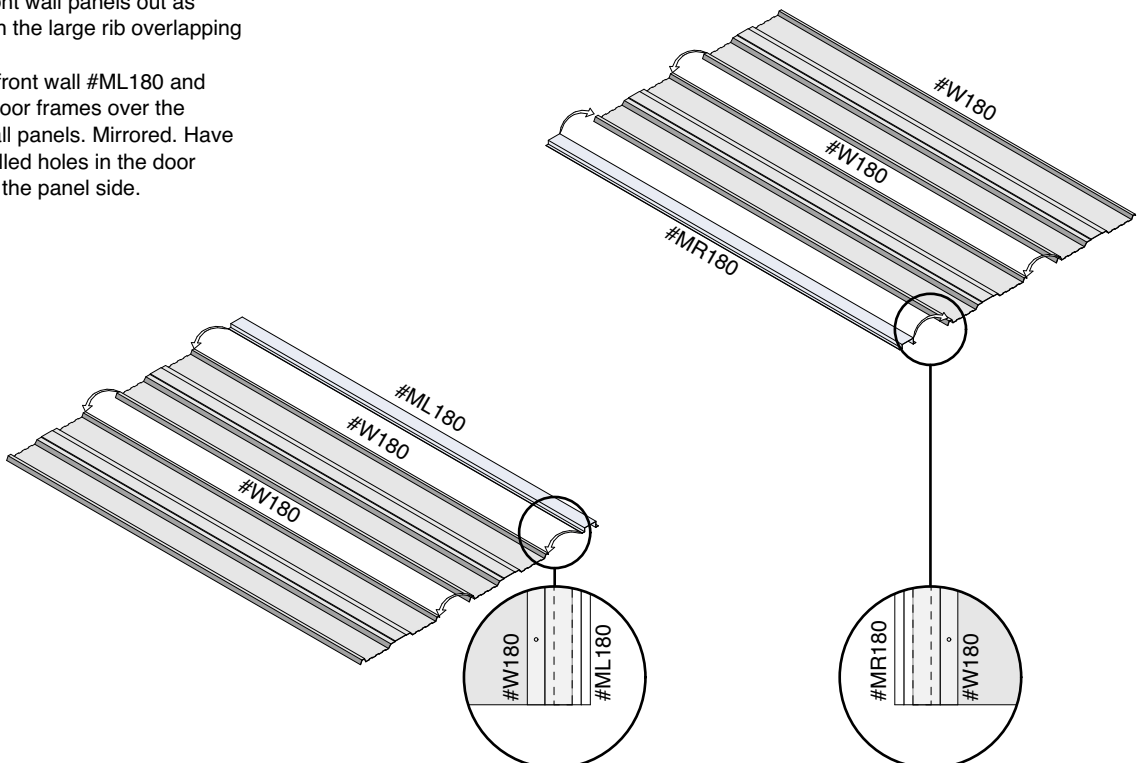



# 4

b

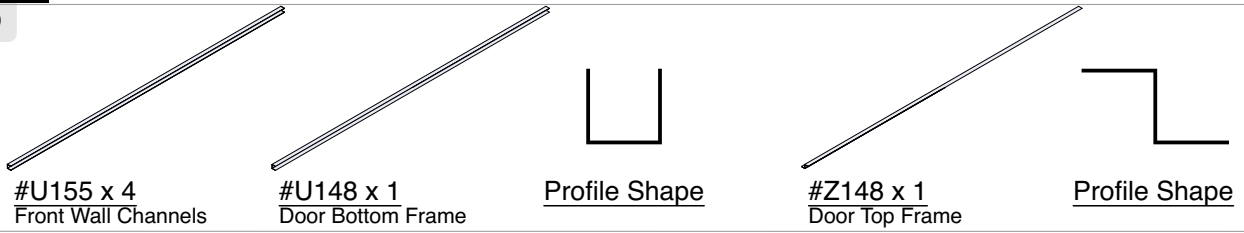

- Slide on the front wall channels, through the slot in the #ML180 and #MR180, until the holes in the top of the channel align with the peaks of the panels.
- Check that the panels are pushed hard into the channel and are perpendicular.
- Push the left and right door frames out to widen the available door opening.

- Slide the #U148 door bottom frame U channel **under** the bottom #U155 U channels.
- Slide the #Z148 door top frame Z channel **under** the top #U155 U channels.
- Position the top and bottom door frames in the centre of the opening before fixing.

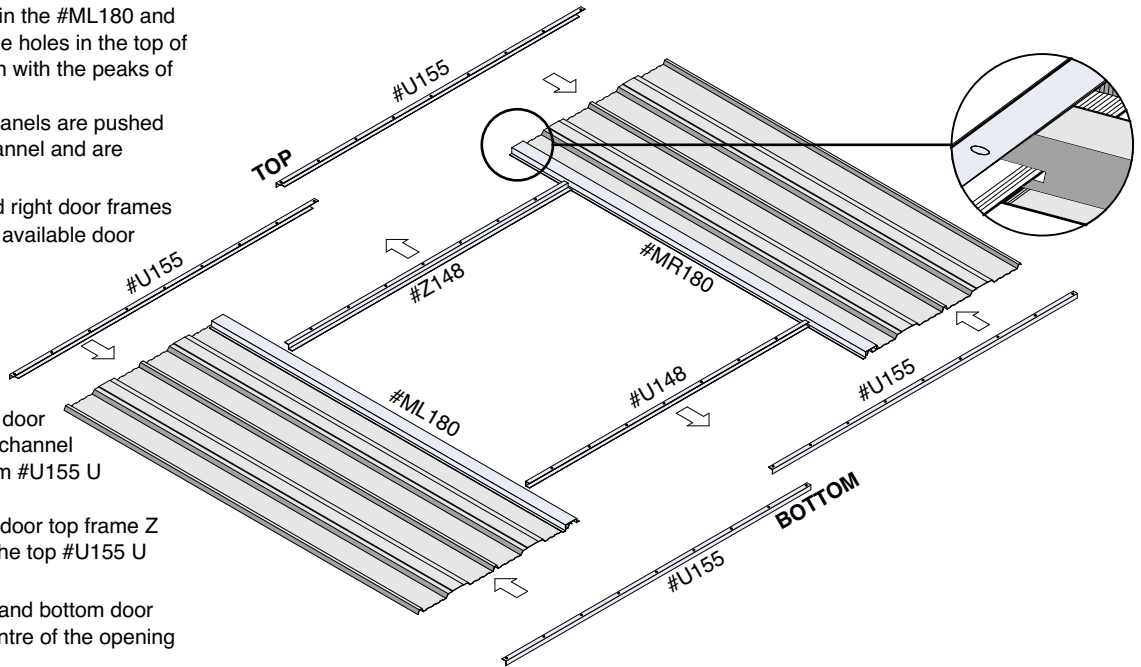

c



Tek Screws

ⓘ All pre-drilled holes should line up with the peaks of the panel. If this varies, squeeze together or stretch out the panels to make sure they align.

**Do not add screws to the #ML180 or #MR180, it will need to be adjusted later on.**

- Screw through the channel holes and through the overlapped panels. Make sure the screws go through all layers.
- Screw through the channel holes and through the top and bottom door frames.
- Do not add screws to the first and last holes or at the #MR180. Indicated with an X in diagram. These need to be left undone.
- Once finished, lay the wall flat out of the way.

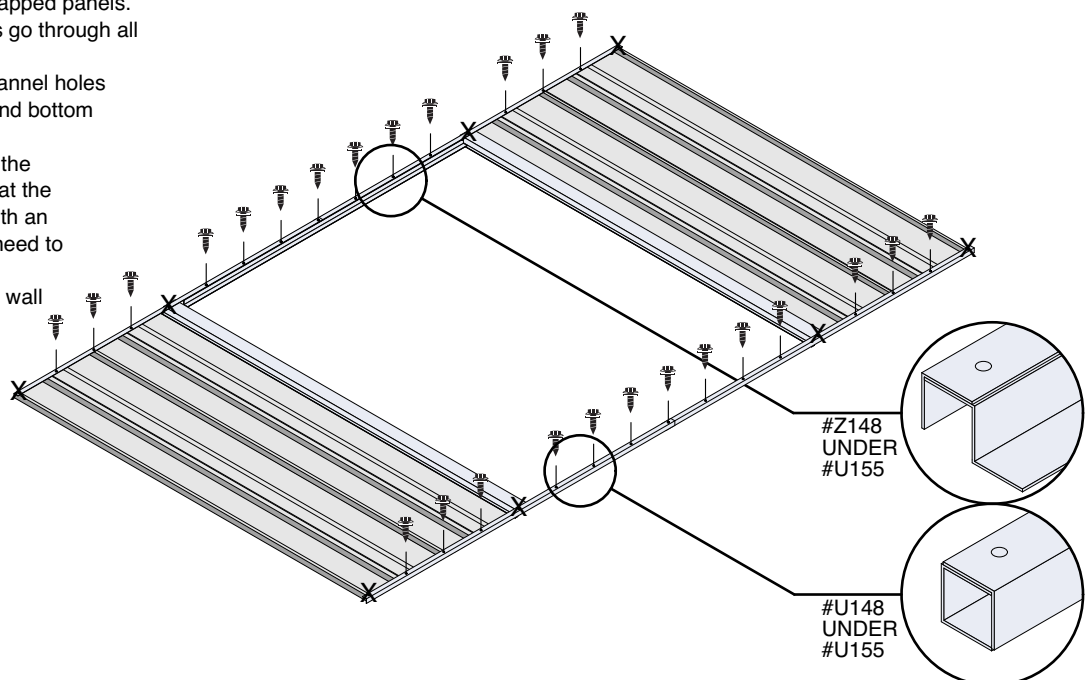

# 5 Assemble the roof

a

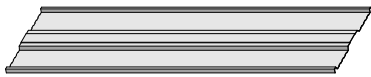

#P100 x 8  
Roof Panels

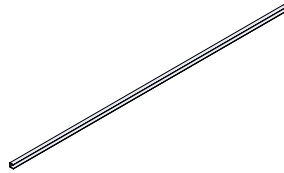

#U155 x 4  
Roof Channels



Profile Shape

- Lay the panels out as shown with the large rib overlapping the small.
- Slide on the roof channels until the holes in the top of the channel align with the peaks of the panels.
- Check that the panels are pushed hard into the channel and are perpendicular.

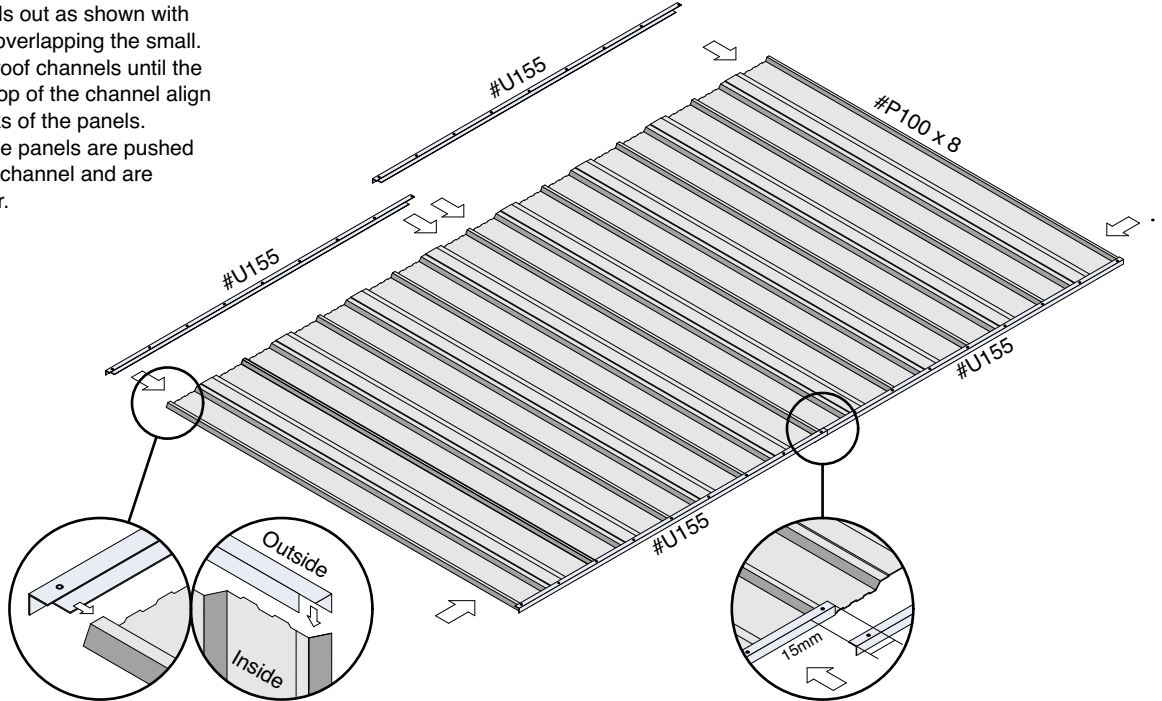

b



Tek Screws

- Screw through the channel holes and through the overlapped panels. Make sure the screws go through all layers.
- Do not add screws to the first and last holes. Indicated with an X in diagram. These need to be left undone.
- Once finished, lay the roof flat out of the way.

ⓘ All pre-drilled holes should line up with the peaks of the panel. If this varies, squeeze together or stretch out the panels to make sure they align.

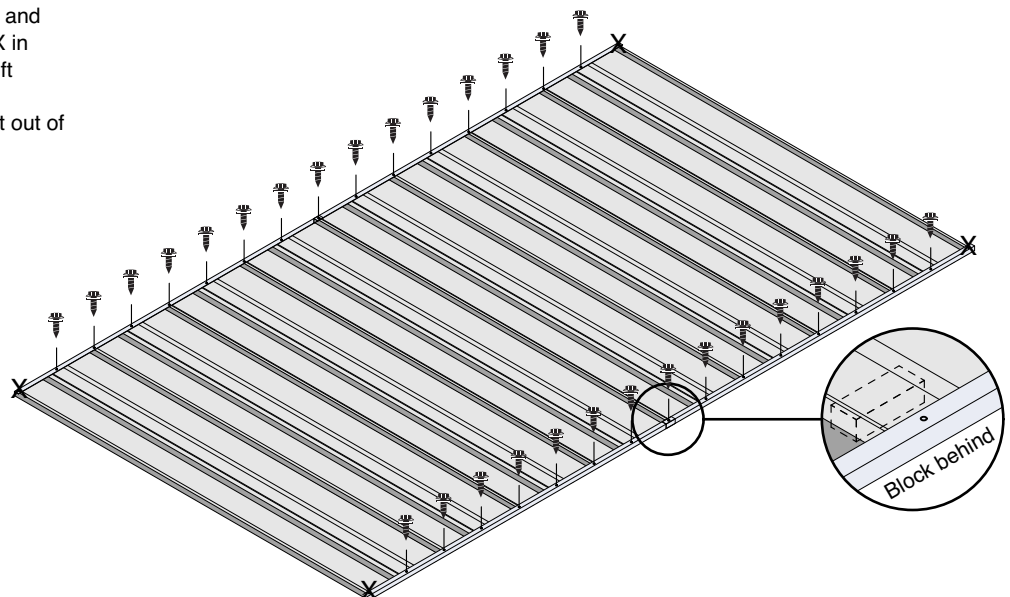

# 6 Assemble the doors

① All panels should overlap by one corrugation.

a

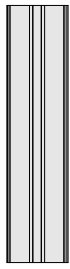

#E175 x 410 x 1  
Door Panel

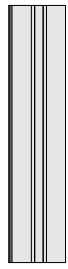

#E175 x 350 x 1  
Door Panel



#U074 x 2  
Door Channel



#U175 x 2  
Door Channel



#D173 x 1  
Door Square Tube

- Lay the panels out as shown with the large rib overlapping the small.
- Slide on the door channels. Place the #D173 in position (dashed) behind the #U175.
- Check that the panels are pushed hard into the channel and are perpendicular.

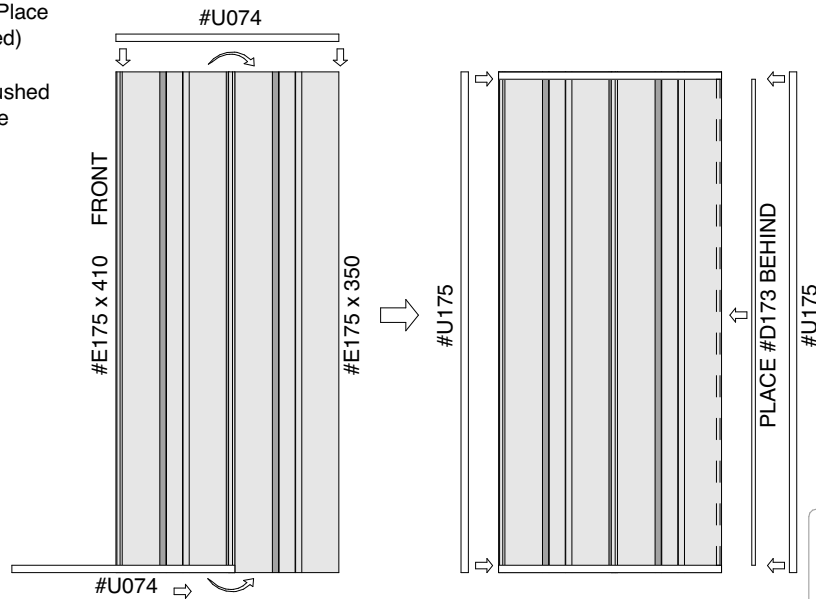

b

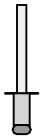

Rivet

- Drill through the channels and the panels / #D173 below in the positions shown with the Ø4.0mm drill bit.
- Using the rivet gun provided, fix the channels together with the rivets. Follow the instructions included on the tool packaging.
- Make sure the rivets go through all layers.
- Ensure the door is square and pieces are pressed firmly together during construction.
- The Door Bar is located in the centre of the door panels. Ensure accurate measuring.

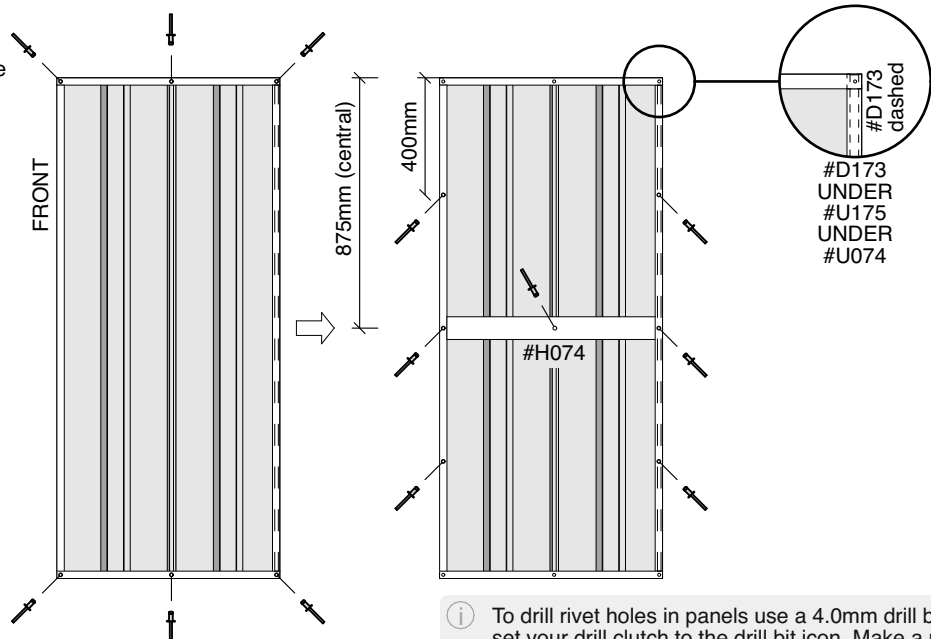

Rivet Gun

① To drill rivet holes in panels use a 4.0mm drill bit and set your drill clutch to the drill bit icon. Make a mark where you want to drill and use this to start the hole. Don't worry if you have placed a rivet incorrectly, they are easy to remove. Just drill directly through the top of the rivet using the same drill bit. This will remove the rivet head, causing the whole rivet to fall out.

# 6 Assemble the doors

C

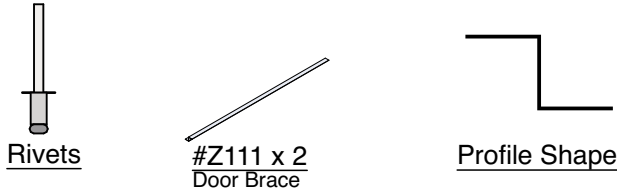

i Use the drill bit to drill pilot holes through the door bracing into the panels. After flipping, fix together using the rivets and spacers through the pilot holes.

- o Flip the partially complete door over so the back side is facing up.
- o Using the Ø4.0mm drill bit, drill through the channels and the panels / #D173 below in the corner positions shown.
- o Using the rivet gun provided, fix the channels together with the rivets.
- o Slide the door braces under the door channels.
- o Drill through the channels and the door braces below in the positions shown.
- o Using the rivet gun provided, fix the channels to the ends of the braces.
- o Do not force the braces too hard as this can distort the door. It is okay to fix one brace to another rather than to the channel.
- o Drill pilot holes through the braces and the panels below in the positions shown.

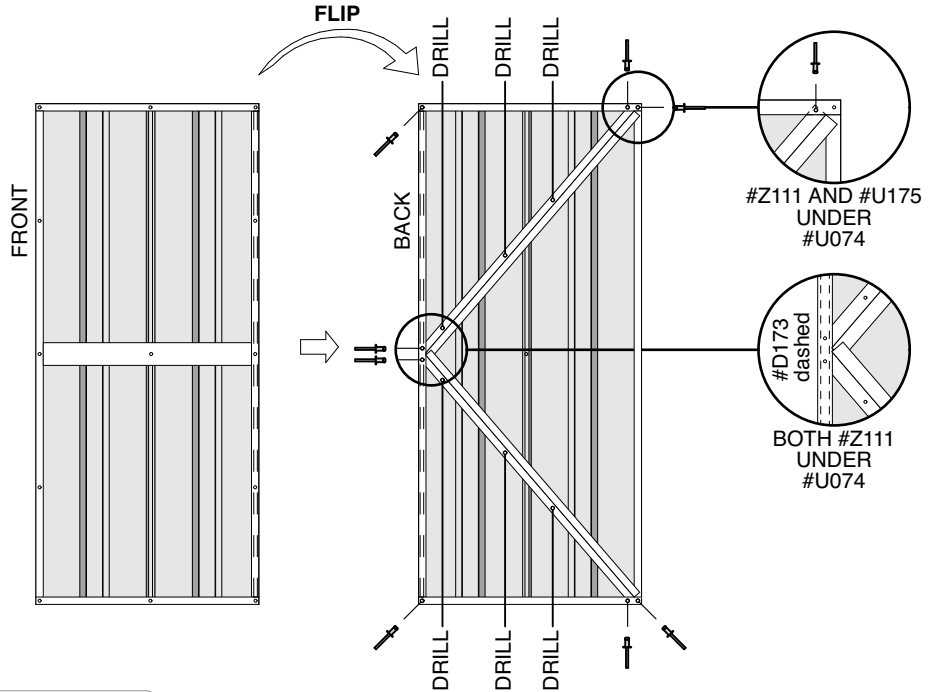

d

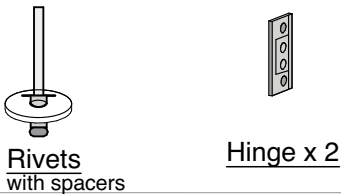

- o Flip the partially complete door over so the front side is facing up.
- o Ensure the pilot holes drilled before are still aligned. If they are not, drill through again from the front side.
- o Prepare 6x rivets with spacers on the wider end.
- o Using the rivet gun provided, fix the panels to the bracing with spacer rivets.
- o Roll the door onto its side. Drill and rivet the door hinges approx. 1 hinge length from the top and bottom of the door. Use the hinge itself as a guide.
- o Attach the smaller side of the hinges to the door channel.

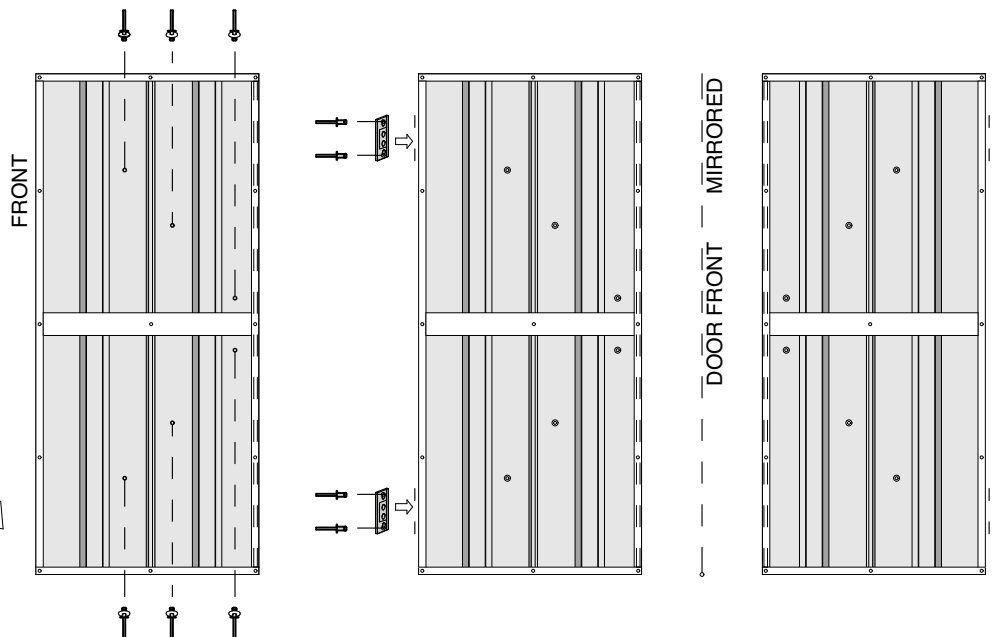

- o Repeat steps 6a-d for the second door. This door will be mirrored. Use the first door as a reference. Make sure the #H074 Door Bars are at the same height and bracing is mirrored.

# 7 Constructing the walls

a



Tek Screws

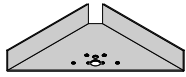

Corner Anchor x 4

① It is very important to have a level foundation prepared to the correct size. A wooden floor, or a concrete slab.

- \* If placing on a pre-prepared wooden flooring slide the corner angles onto edge bearers, under the perimeter floor board (this is why a nail was left out in the corner).
- Have a friend hold the back wall in place as shown. If the wall is large, a wheely bin or stepladder are sufficient alternatives.

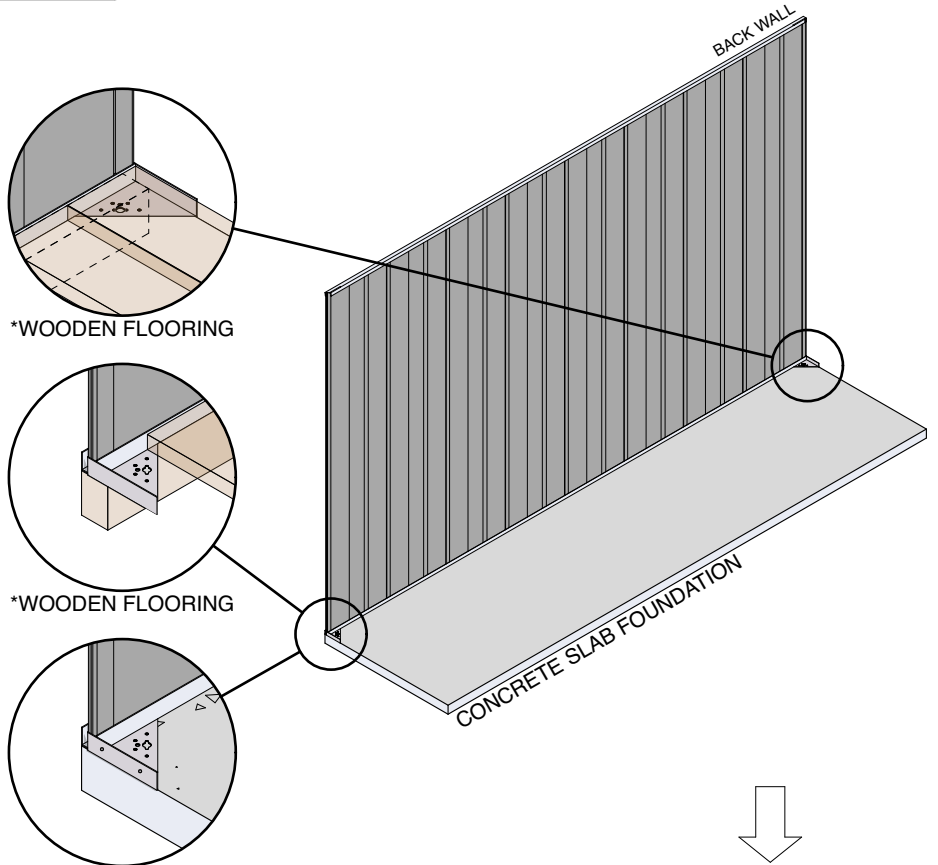

- Have the same friend hold the side wall at the same time, at a right angle to the back wall, over the placed corner anchor below.
- The wall channel flaps should overlap each other in the corner and just touch at right angles as seen from the outside.
- Fix through the corner anchor to the wall channel top and bottom. It is easier to start with the top to relieve your friend from holding duties early.
- When on flat flooring, place a spirit level or timber block under the shed corner. This will ensure the walls stay at the same height as you drill screws into corner anchor.
- After the top and bottom corner anchor is fixed, screw through the overlapping panels from the outside to make the shed weathertight.

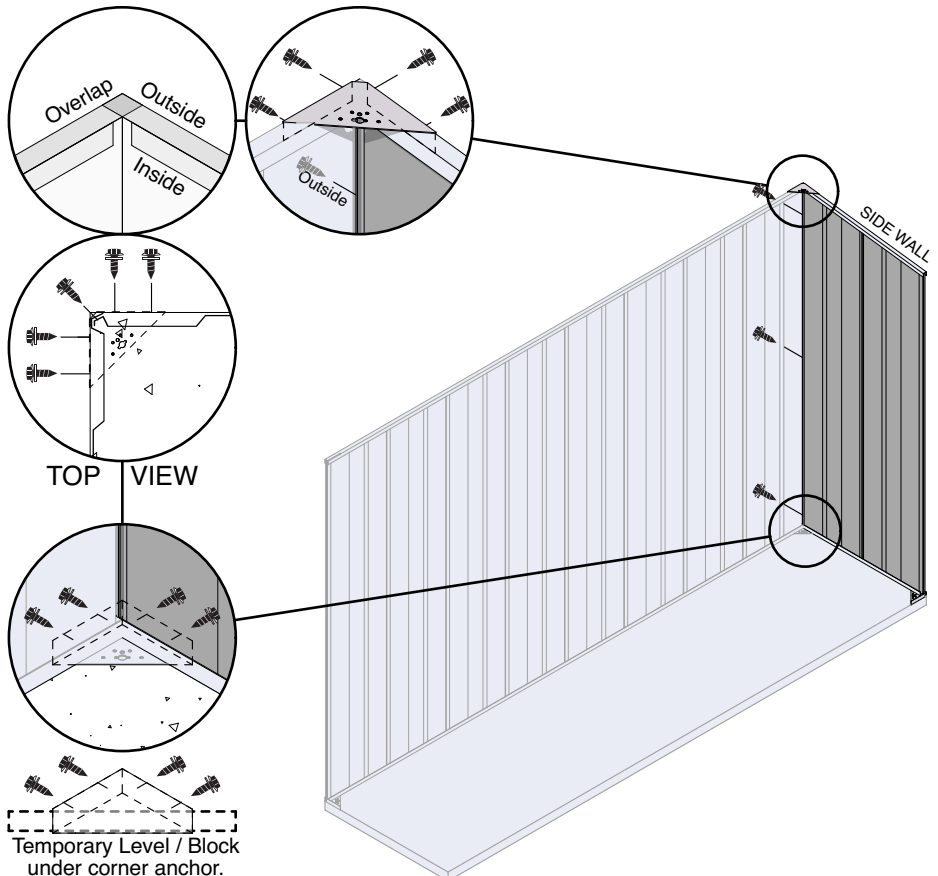

Optional:

- Once the walls are up and the edges of the panels overlap, we suggest running sealant up the full height between the corner overlap before fixing. This will protect the shed more from heavy weather.



Tek Screws

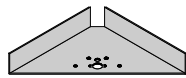

Corner Anchor x 4

- Hold the side wall at a right angle to the connected back and side walls, over the placed corner anchor below.
- The wall channel flaps should overlap each other in the corner and just touch at right angles as seen from the outside.
- Fix through the corner anchor to the wall channel top and bottom. It is easier to start with the top to relieve your friend from holding duties early.
- When on flat flooring, place a spirit level or timber block under the shed corner. This will ensure the walls stay at the same height as you drill screws into corner anchor.
- After the top and bottom corner anchor is fixed, screw through the overlapping panels from the outside to make the shed weathertight.

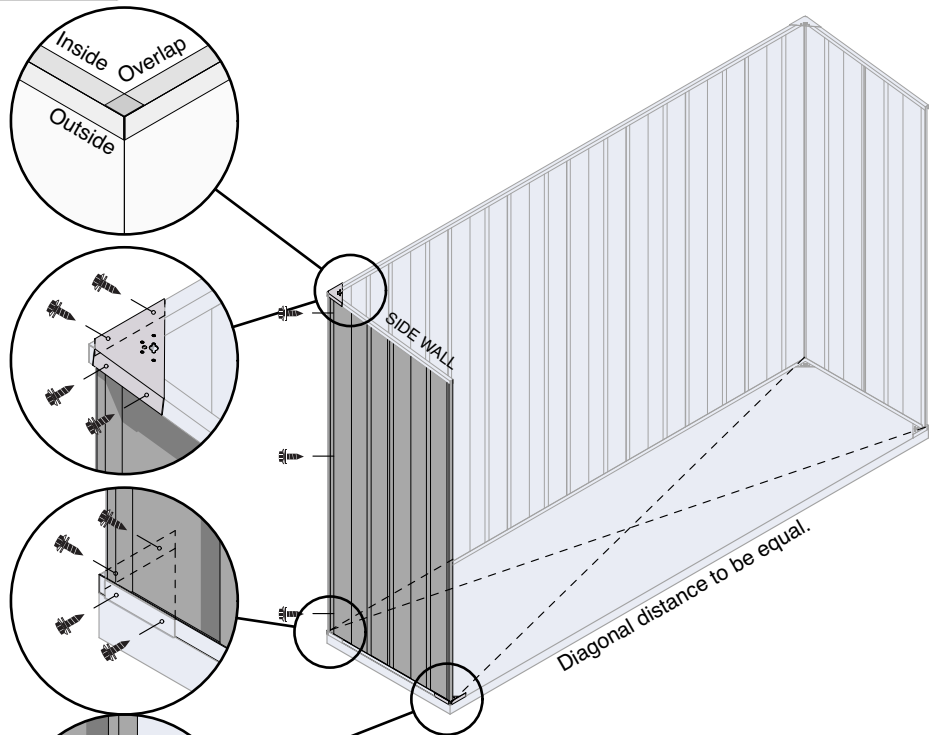

- Hold the front wall between the connected side walls, over the placed corner anchors below.
- When on flat flooring, place a spirit level or timber block under the shed corner. This will ensure the walls stay at the same height as you drill screws into corner anchor.
- The far corner of the shed in the diagram is connected the same as the corners previously.
- After the top and bottom corner anchor is fixed, screw through the overlapping panels from the outside to make the shed weathertight.
- The top and bottom door frames should butt hard into the vertical door frame at right angles as seen from the top.
- Fix through the corner anchor to the wall channel top and bottom. It is easier to start with the top to relieve your friend from holding duties early.
- Check the squareness of the shed. The diagonal measurements need to be equal.

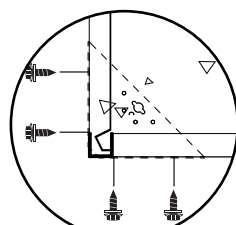
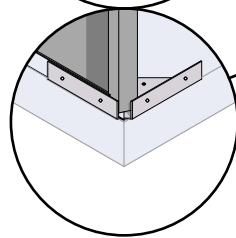

TOP VIEW

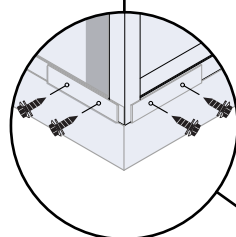

## Optional:

- Once the walls are up and the edges of the panels overlap, we suggest running sealant up the full height of the corner before fixing. This will protect the shed more from heavy weather.

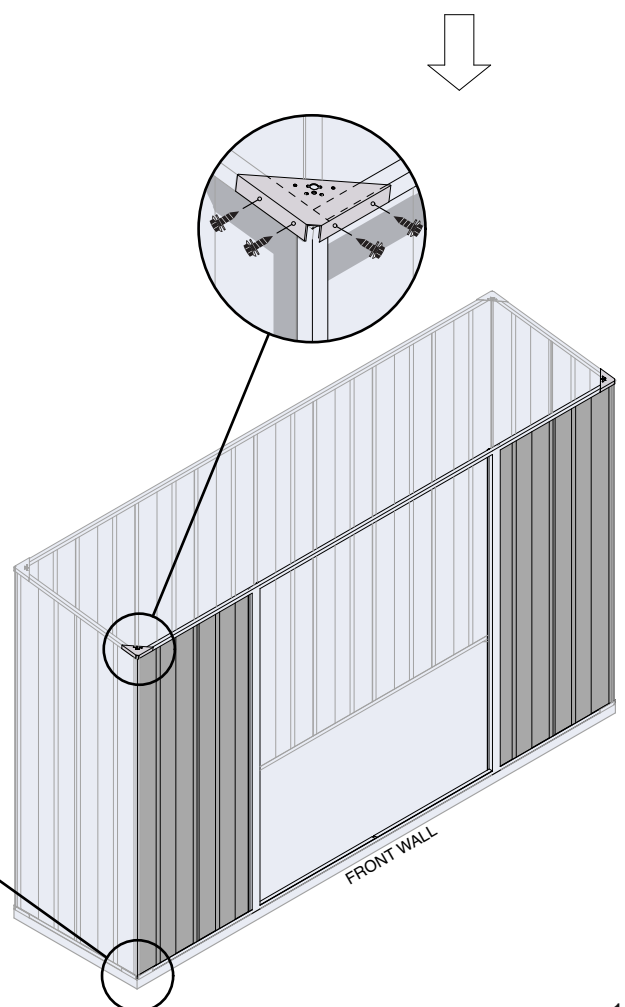



# 8 Installing the bracing

a

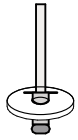

Rivets  
with spacers



Rivet Gun

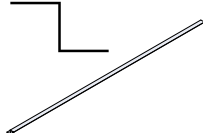

#Z130 x 4  
Wall Bracing

- Hold a single #Z130 wall bracing profile, lapped underneath the middle of the wall top channel. Hold it diagonally. Drill through the bracing channel and wall panel with the Ø4.0mm drill bit, at the middle point between ribs. Drill the hole from standing inside the shed.
- After creating a hole through both layers, have a friend insert a rivet with spacer from the outside and engage the rivet with the rivet gun supplied.
- Repeat the above steps with the lower diagonal brace, drill through the middle point between lower ribs.
- Where the two braces overlap in the middle, drill and rivet as shown, from the outside, in the middle between ribs. A tek screw from the inside is optional.
- Repeat again for all diagonal braces in positions indicated.

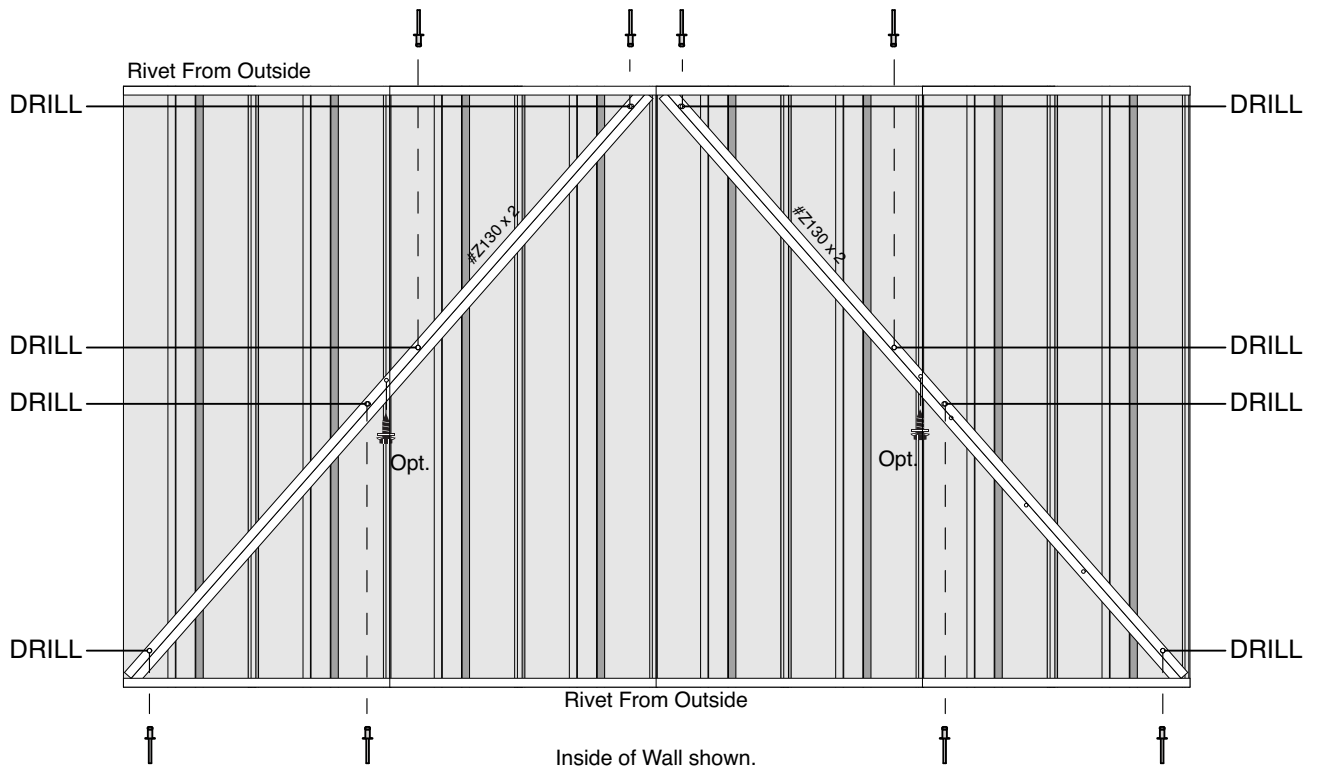
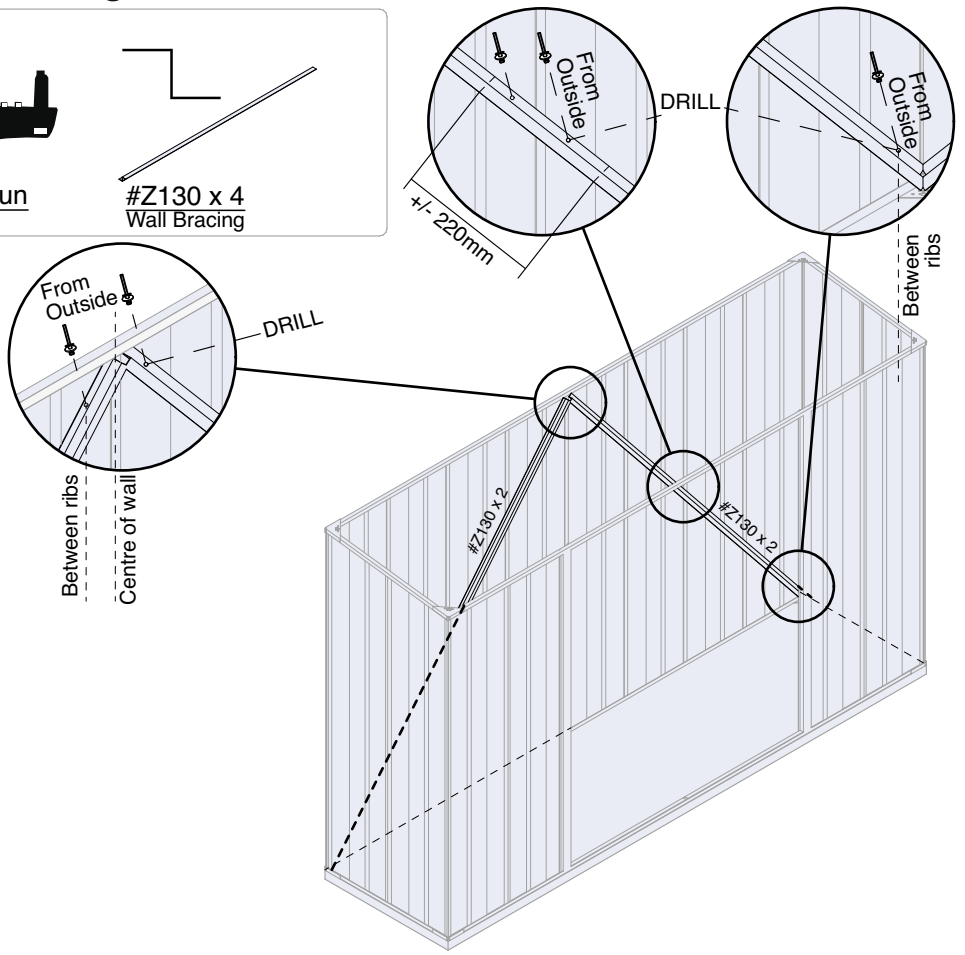

# 9 Constructing the roof

a



**Tek Screws  
with Spacers**

- Check the squareness of the shed. The diagonal measurements need to be equal.
- Place the prepared roof panel loosely on top of the now assembled walls and align the edges with the side walls.
- Maintain an equal overhang to the front and the back walls. This is usually close to 100mm.
- Prepare tek screws with spacers on the ends. This helps with shed weather tightness.
- The edge of the roof needs to be parallel with the edge of the wall. Do this by transferring the same offset from below the overhang to on top with a measuring tape, just add 10mm to find the centre of the top of the wall channel. It is recommended to start in the corners and screw in the base of every second corrugation.
- Twist the shed where required to maintain the roof alignment with the side walls and keep the shed square.

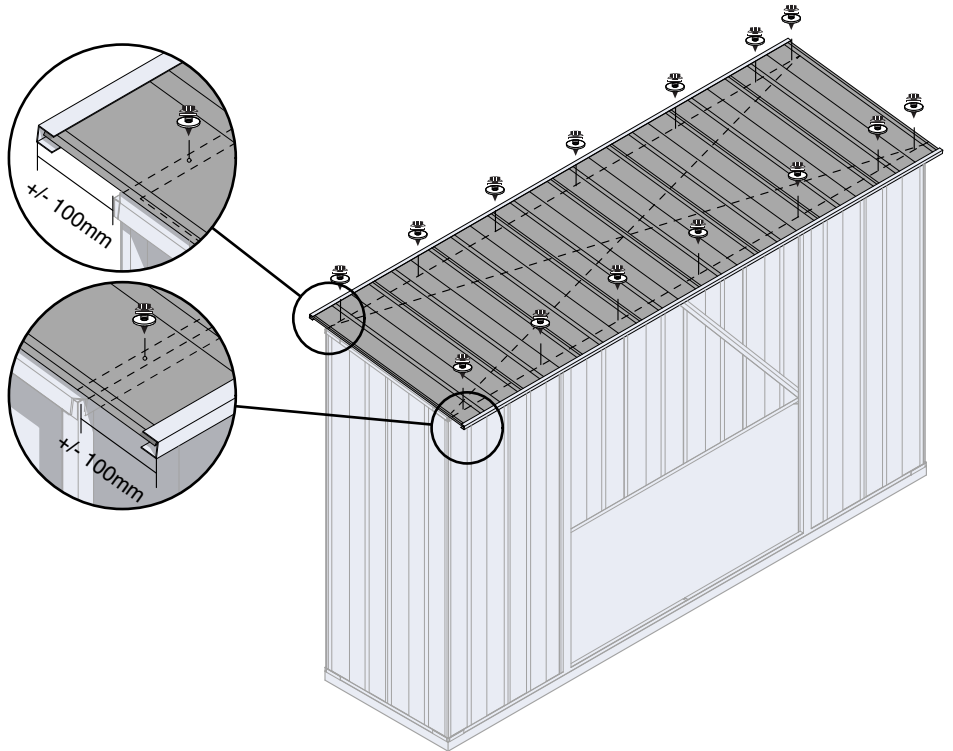

b



**Tek Screw**

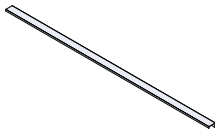

**#G100 x 2  
Roof Channel**



**Profile Shape**



**Corner Cover x 4**



- Once the roof is fully secured, push the #G100 Roof Channel over the edge of the panels and into the top wall channels front and back.
- Cover the corner of the roof, over the roof channels, with the plastic corner covers. Screw these in place with a single self drilling tek screw each. This screw should go through the both channels.
- There should not be any need to climb on the roof.

Optional:

- You may also screw through the centre of the side roof channel, through to the top of the side wall channel.
- Use tape to cover over the insides of the shed, all around, between the top of the wall channels and the underside of the roof panels. Shown dashed in the cut view.

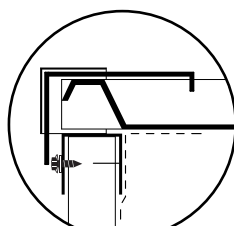

**CUT VIEW**

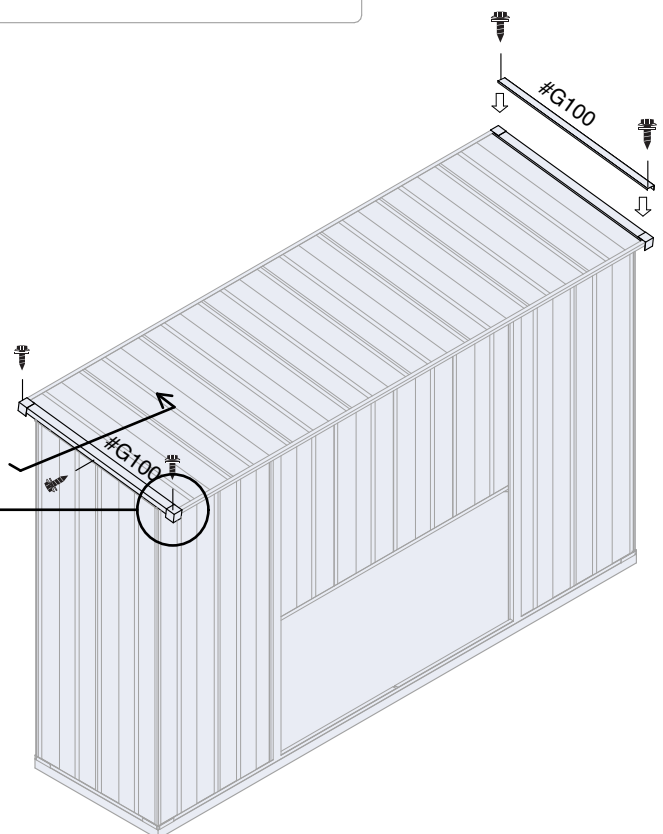
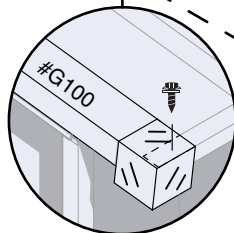



# 10 Installing the doors



Phillips Head Screw

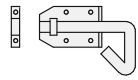

Bolt (Outside)



Bolt (Inside)

- Have your shed building buddy hold one of the two assembled doors open with the hinges aligned with the right door frame #MR180. The top and bottom of the door should fit easily within the frame of the front wall.
- Centralise the door vertically and screw through one of each of the hinges holes, through to the #MR180 only, using the phillips head screws provided. The screws are self drilling and do not require a pilot hole.
- With one screw in each hinge and the right door frame free to move side to side check that the door can close easily and is at the correct height.
- If the door is hanging at the correct height you are free to screw the remaining screws into the hinges.
- Repeat the above steps with the left door onto the #ML180.

## Optional

- If you would like a more permanently hung door the screws can be replaced with rivets. This does limit future adjustments.

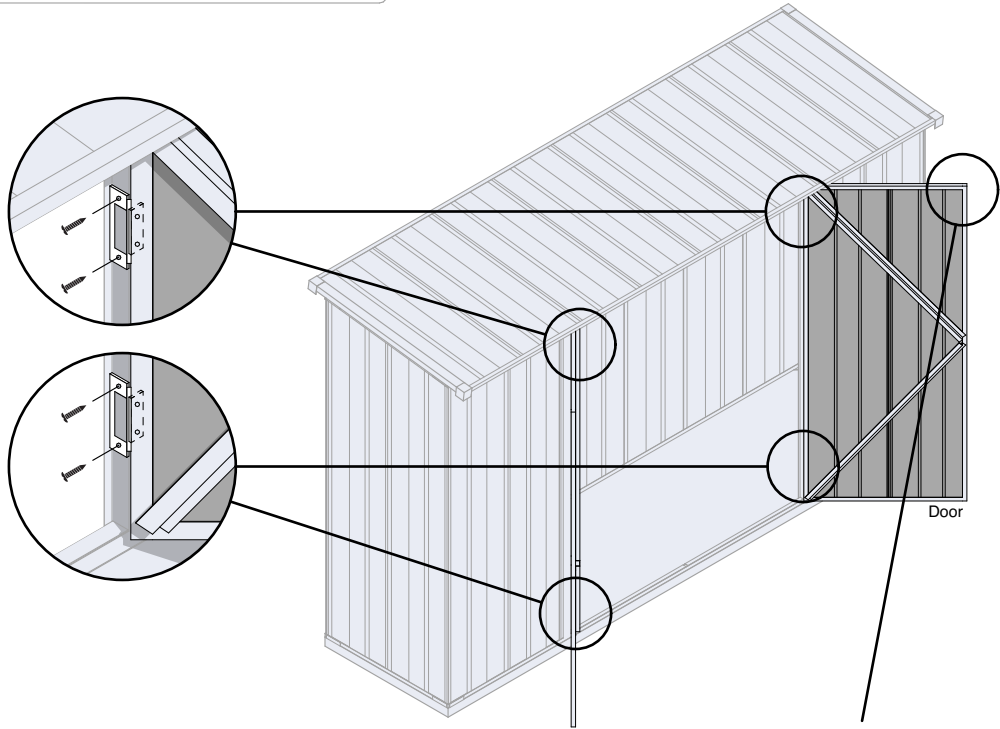

- The door frames should not have had any screws fixing them in place and the doors should be able to be adjusted by moving the frame until the doors sit happily together in the door frame.
- Once you are satisfied with the door positions, add screws to secure the door frames to the top and bottom front wall channels.
- The doors should be able to swing open and closed without hitting the frame or each other but also be close enough to allow for bolt install.
- Screw through the door frames and through the front wall panel to secure the frame vertically.
- Use screws to attach the inside door bolt to the top of the door that you decide should stay 'closed'. Too tight will affect performance. Pilot holes may be required.
- Use phillips head screws to first secure the bolt to the 'open' door bar, #H074, and then to secure the bolt keeper to the 'closed' door. Pilot holes may be required here as any scratches made will be visible.

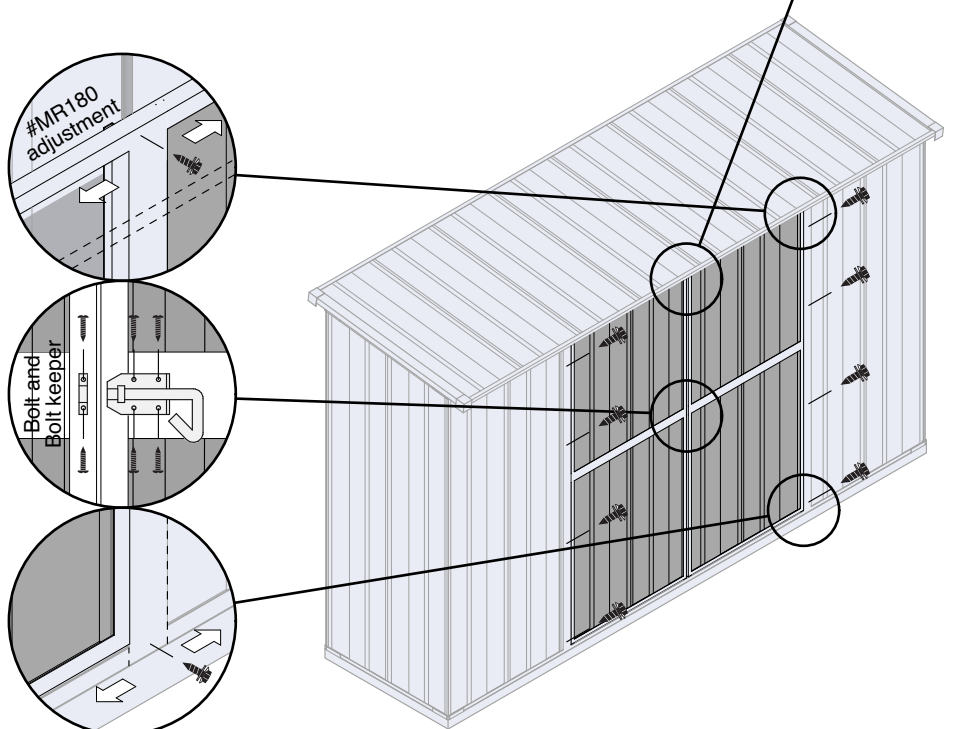
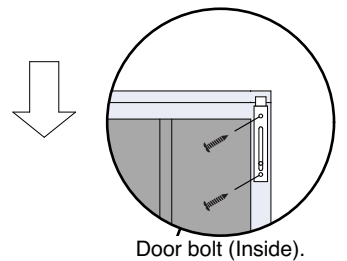

## 11 Fixing to the floor



Wood Anchor Screw  
Or Concrete fixings



Hook Anchor



Screw sheath

- Place screw head sheaths to any exposed screw heads within the shed. Most noticeable are the screws through the front wall panel behind the right door frame.
- If the shed is sitting on top of a wooden platform (not a flooring kit), use the wood anchor screws and the hook anchors to secure the bottom wall channels and the corner anchors to the flooring.
- If the shed is sitting on a Trade Tested flooring kit, use the wood anchor screws to secure the bottom wall channels to the bearers.
- If the shed is sitting on a concrete foundation, use concrete screws (not included in kitset) and the hook anchors to secure the bottom wall channels to the flooring.

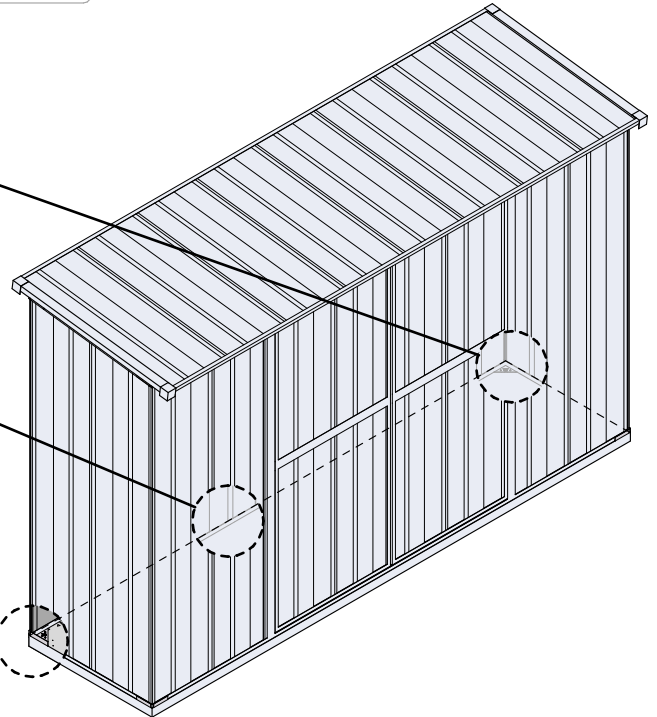
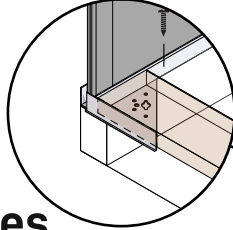
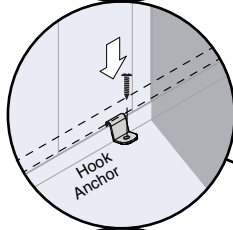
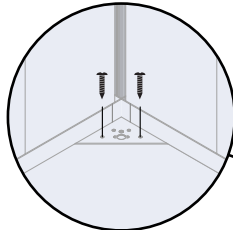

## 12 Finishing touches



Display of Pride



Misc. Items

- Congratulations. You are finished!
- Review the instruction manual and make sure you haven't missed any important steps.
- The shed has enough fastenings to be very durable throughout a range of weather conditions.
- There are extra fixings included in the kitset, just in case you wish to make any further adjustments or hang items from walls. Just be sure to use the spacers on tek screws through walls to keep water out.
- Use silicone to further weatherproof around the shed (not included).
- **If you are having any issues during assembly, or decide you require an assembly service, just give us a call on 0800 800 880 or email [support@tradetested.co.nz](mailto:support@tradetested.co.nz) - our friendly team are here to help!**

**i** **Make sure you remove metal drill filings.** This will avoid scratches and will help prevent any corrosion later on. Peel off part number stickers with a cloth, soap and water.

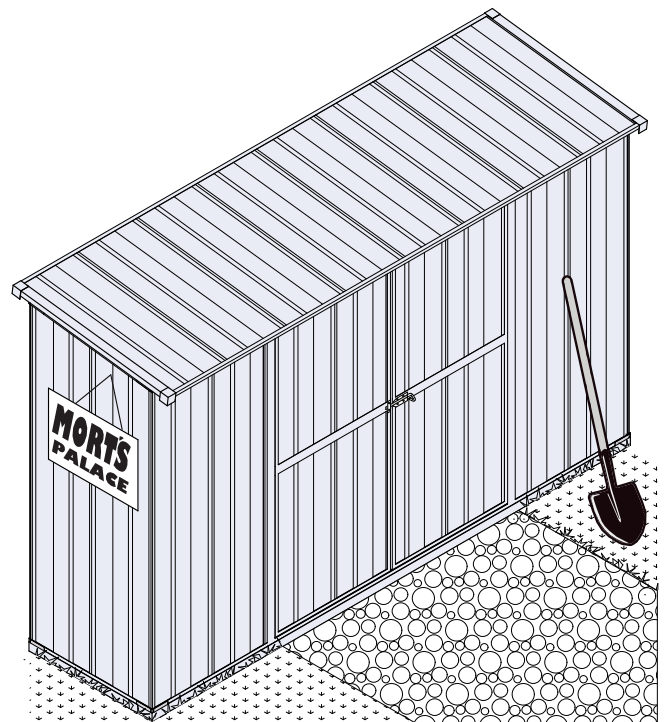

## Reference images



Corner Anchor Interior - Top



Door Frame - Top

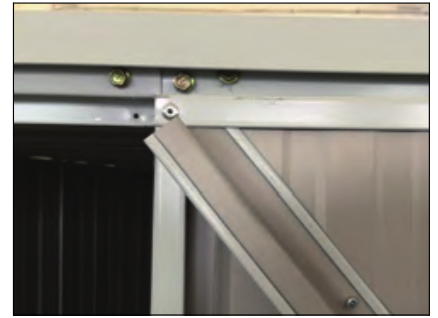

Door Bracing - Top



Corner Anchor Exterior - Bottom



Door Hinge



Door Bracing - Centre



Corner Cap



Pad Bolt



Door Bar



Hook Anchor



Corner Anchor Interior - Bottom



Door Bracing - Bottom

# Care & Maintenance

---

## FINISH

For a long lasting finish, periodically clean and wax the exterior of your unit. Touch up scratches as soon as you notice them.

**Remember to make sure you remove any metal drill filings after construction to help prevent any corrosion and scratches.**

## ROOF

Keep the roof clear of leaves and snow with a long handled, soft-bristled broom. Heavy amounts of snow on the roof can damage the structure, making it unsafe to enter.

## DOORS

Keep doors closed and locked to prevent wind damage.

## FASTENERS

Use all washers supplied to protect the shed panels against weather. Regularly check your building for loose screws or bolts and retighten them as necessary.

## OTHER TIPS

- Do not store swimming pool chemicals in your building as they can cause corrosion.
- Use silicone caulking to further watertight seals throughout the building.
- Peel off part number stickers with a cloth, soap and water.
- Use silicone to further weatherproof seals around the shed (not included).

**tradetested**

# CONGRATS ON YOUR NEW SHED!



Stoked with your shed? Take a photo and leave us a review or tag us @tradetested on social media, we'd love to see it!

